

STACK WASHER/DRYER

9KG WASHER & 10.5KG DRYER

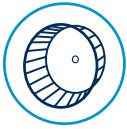

MLE22 AND MLG22



TURBOVENT® SYSTEM

- A high-speed blower wheel optimizes performance in long vents
- High airflow helps reduce drying times for a wide variety of loads
- Helps to increase efficiency and turns over the life of the machine



INTELLIGENT CONTROLS WITH M-SERIES TECHNOLOGY

- Easy-to-read diagnostics assist with quick identification of an issue helping to get the machine back into service
- Can be upgraded to Card Reader only to prevent vandalism and increase safety in your laundry
- End users can easily choose their preferred wash experience with one-touch cycle selection
- Digital display clearly conveys prices, selections, and time remaining

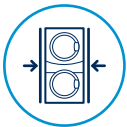

SPACE-SAVING CONFIGURATION

- All within the floor space of a single unit, the large capacity of the 9kg washer provides ample room for bulky items, while the extra-large, 10.5kg dryer allows for loads to be dried effectively
- Saving space can still deliver an optimal cleaning experience for end-users and help maximize laundry throughput



BUILT TO LAST

- Porcelain enamel top — a durable finish that stands up to the demands of high-traffic
- Premium bearings — oversized premium NSK bearings are sealed for added protection of the drive system
- Robust hinge — heavy-duty, die-cast door hinge is built to withstand the rigors of commercial laundry



NON-COIN
MLE22PR (pictured)
Also available in gas

9kg Stack Washer/10.5kg Dryer		
Payment Configuration	Electric	Gas
Non-Coin	MLE22PR	MLG22PR
Coin Drop or Card Reader Ready	MLE22PD	MLG22PD



COIN DROP OR CARD READER READY
MLE22PD (pictured)
Also available in gas



See maytagcommerciallaundry.com for warranty details.

STACK WASHER/DRYER

9KG WASHER & 10.5KG DRYER



MLE22 AND MLG22

SIDE VIEW

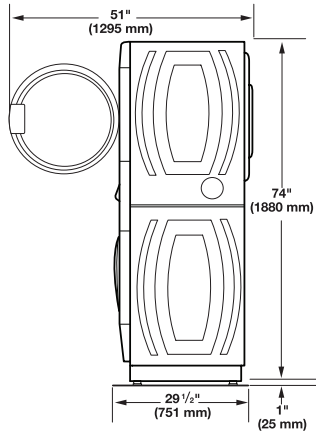

BACK VIEW

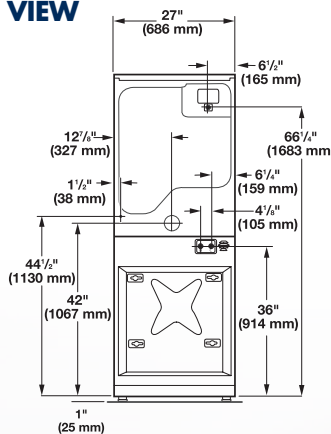

Maximum Exhaust Duct Length Per Number of Turns

No. of 90° Turns	Rigid Metal Vent	
	Box Hood and Louvered Style	Angled Hood Style
0	39.6 m	39.3 m
1	38.1 m	36.3 m
2	35.1 m	33.2 m
3	32.3 m	30.5 m
4	29.9 m	28.0 m



*Use 4" (100 mm) diameter rigid aluminum or galvanized steel duct. Never use plastic, non-metal or combustible duct. See specific instructions for proper installation. Because of continuous product improvement, Maytag reserves the right to change specifications without notice. Export model ships without coin-drop mechanism.

Printed on Recycled Paper.

MODELS	MLE22PD MLE22PR	MLG22PD MLG22PR
COIN DROP / CARD READY NON-COIN		
Fuel Type	Electric	Gas
CAPACITY		
Washer	9kg	9kg
Dryer	10.5kg	10.5kg
DIMENSIONS		
Width — mm	686	686
Depth — mm	751	751
Height — mm	1,880	1,880
Door Opening — mm	362	362
Exhaust Duct Diameter — in. (mm)	4 (100)*	4 (100)*
CRATED DIMENSIONS		
Crated Width — mm	743	743
Crated Depth — mm	864	864
Crated Height — mm	1,924	1,924
APPROXIMATE WEIGHT		
Uncrated — kg	169	171
Crated — kg	173	176
REQUIREMENTS		
Voltage	220-240V - 50Hz	220-240V - 50Hz
Breaker/Fuse — amps - total per stack	25	10
Dryer Airflow — CFM (CMM)	215 (6.1)	230 (6.5)
Dryer Electric Heating Element (watts)	4,600	N/A
Dryer Gas Rating — BTU/hr (kcal/hr)	N/A	20,000 (5,040)
Dryer Gas Inlet Size — in.	N/A	3/8 N.P.T.
Dryer Motor Size — HP (kW)	1/3 (0.25)	1/3 (0.25)
Washer average water usage	40.5 Liters	
Washer Extraction Speed	300 G'Force / 1000 RPM	
Washer Motor Size	.09hp / .07Kw	



FLUING & DUCTING ACCESSORIES FOR MAYTAG COMMERCIAL DRYERS



100mm THROUGH WALL KIT (STAINLESS STEEL)
Part Number: DVS1SS



GRAVITY VENT - MARINE GRADE STAINLESS STEEL 100mm
Part Number: GVSS100



RIGID GALV DUCTING 100mm x 1200mm
Part Number: PPS04430



DRAFT BLOCKER 100mm
Part Number: DBV100



ADJUSTABLE ELBOW 0-90 DEGREES - 100mm
Part Number: ELB049030



INTERNAL SIDE FLU KIT - TO CHANGE DRYER VENTING
Part Number: W10470674



INDOOR LINT FILTER TRAP*
Part Number: LTF



FLEXIBLE DUCTING* 100mm x 2.4m
Part Number: AO48MX/9



DRYER VENT CLEANING BRUSH
Part Number: DVBRUSH8

*Not recommend for commercial use. Can only be used on Electric Dryers. Additional specialised fluing parts can be organised through our spare parts department.



Maytag Commercial Install Summary



MAT20 & MAT23 Top Load Washer

- Standard 10AMP GPO within 1.0m to plug into
- ¾" hot and cold water taps within 1m
- Standpipe or laundry drain minimum 77cm high

Before operation:

- Installation manual to be read
- Unit to be levelled



MHN33 Front Load Washer

- Standard 10AMP GPO within 1.0m to plug into
- ¾" hot and cold water taps within 1m
- Standpipe or laundry drain minimum 77cm high – if supplied on plinth, laundry drain to be 102cm high

Before operation:

- Installation manual to be read
- Shipping bolts to be removed
- Power cord to be pulled through
- Unit to be levelled

MDE20 or MDE28 ELECTRIC Dryer.

- No power cord supplied - requires hardwiring into a dedicated 1 phase 25AMP circuit by your electrician.
- Requires fluing to external air using single skin 100mm rigid galv²

*Natural gas as standard - LPG Conversion Kits available.

Before operation:

- Installation manual to be read
- Unit to be levelled

MDG20 or MDG28 GAS Dryer.

- Standard 10AMP GPO within 1.0m to plug into
- Licensed gas plumber required to connect to gas and fluing on site
- Requires fluing to external air using single skin 100mm rigid galv²

*Natural gas as standard - LPG Conversion Kits available.

Before operation:

- Installation manual to be read
- Unit to be levelled

Install summary is a brief guide only and does not cover all requirements.

Full installation manual is supplied with each machine as hard copy and is also available via email on request.

1 – Clearances are minimum for dryer free air requirements. Additional clearances may be required depending on fluing and supply requirements on site.

2 - All dryers must be flued to external air with rigid galvanised ducting. Dryers in outdoor areas require fluing to direct heat and lint away from unit. Multiple /group dryer ducting requirements as per installation manual.

Ducting available from Dependable Laundry Solutions.



Maytag Commercial Install Summary

MLE22PN/PR/PD ELECTRIC Stack Washer/Dryer

- No power cord supplied - requires hardwiring into a dedicated 1 phase 25AMP circuit by your electrician.
- ¾" hot and cold water taps within 1m
- Standpipe or laundry drain minimal 77cm high
- Minimum 110mm clearance behind unit¹
- Requires fluing to external air using single skin 100mm rigid galv²

Before operation:

- Installation manual to be read
- Shipping bolts to be removed
- Unit to be levelled
- Service key is bubble wrapped in machine drum – needs to be stored & kept



MLG22PN/PR/PD GAS Stack Washer/Dryer

- Standard 10AMP GPO within 1.0m to plug into
- ¾" hot and cold water taps within 1m
- Standpipe or laundry drain minimal 77cm high
- Minimum 110mm clearance behind unit¹
- Requires fluing to external air using single skin 100mm rigid galv²
- Licensed gas plumber to connect to gas and fluing

*Natural gas as standard - LPG Conversion Kits available.

Before operation:

- Installation manual to be read
- Shipping bolts to be removed
- Power cord to be pulled through
- Unit to be levelled
- Service key is bubble wrapped in machine drum – needs to be stored & kept.

MLE27PN/PD ELECTRIC Stack Dryer/Dryer

- No power cord supplied - requires hardwiring into a dedicated 1 phase 50AMP circuit by your electrician.
- Minimum 110mm clearance behind unit¹
- Requires 2 x fluing to external air using single skin 100mm rigid galv²

Before operation:

- Installation manual to be read
- Unit to be levelled
- Service key is bubble wrapped in machine drum – needs to be stored & kept

MLG27PN/PD GAS Stack Dryer/Dryer

- Standard 10AMP GPO within 1.0m to plug into
- Minimum 110mm clearance behind unit¹
- Requires 2 x fluing to external air using single skin 100mm rigid galv²
- Licensed gas plumber to connect to gas and fluing

*Natural gas as standard - LPG Conversion Kits available.

Before operation:

- Installation manual to be read
- Unit to be levelled
- Service key is bubble wrapped in machine drum – needs to be stored & kept

